

How to Install Electric Load Sensor

Proteus C5 WiFi Electric Load Sensor monitors current flowing through a power cord to determine whether the load is ON or OFF. After you have completed the Wi-Fi Setup process outlined in the Quick Start Guide, Clamp the sensor node to the power cord, and connect the node to the base unit by either directly plugging it into the stereo port or via the extension cord included.

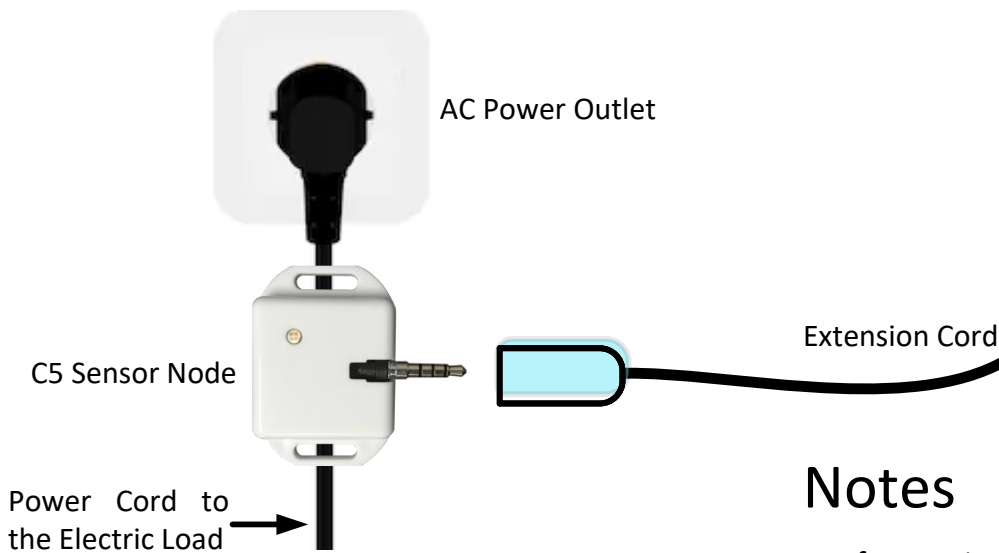

Electric Load
(representative only)

Notes



1. After setting up your sensor, if it starts to beep or goes to alarm, don't worry. The sensor may need additional settings update to match with the type of load you have. See next page for details.
2. Proteus C5 is an electric load ON/ OFF sensor. It cannot calculate the power / energy used by the load
3. Proteus C5 monitors current, and not voltage.
4. Proteus C5 requires atleast 500mA to detect ON.

Emails, Calls, Text Alerts

You can add your phone numbers, multiple emails to the notification list. No matter where you are, you can be in the know when an alarm is tripped.

Testing Your Sensor

After the installation is complete, depending on the type of load you are monitoring, read further on how to configure the settings, and test your sensor.

Types of Loads

There are different types of electric loads.

1. Loads that are normally OFF. Turns on at no predictable intervals. Eg: Sump pump, backup generator, etc.
2. Loads that are normally ON. Eg: Main Pump/ Motor.
3. Loads that go ON and OFF, at predictable intervals based on specific conditions. Eg: Fridge, AC,

Configurations available on C5

Once you have the Proteus C5 connected to Wi-Fi and you are able to login to the cloud, it is time to get familiar with the different configuration settings available to you in order to set them correctly for proper operation.

1. Normal State

Depending on your load, you need to select the normal state of your sensor.

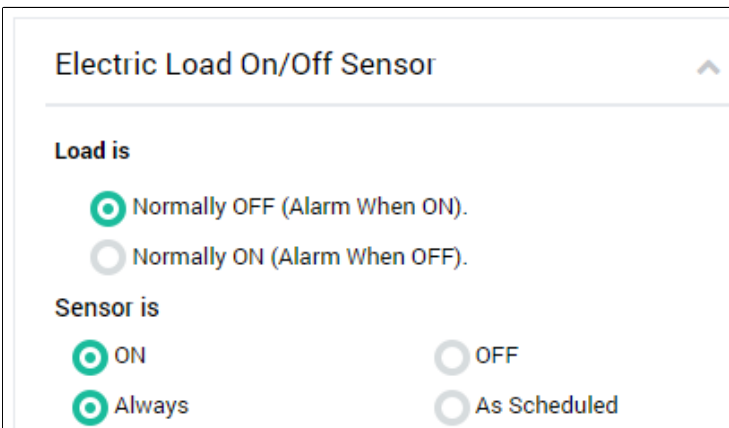

Electric Load On/Off Sensor

Load is

Normally OFF (Alarm When ON).

Normally ON (Alarm When OFF).

Sensor is

ON OFF

Always As Scheduled

2. Monitoring Schedule

By default, the sensor is scheduled to monitor all the time. But if you want the sensor to be active only during certain days of week/ hours of day, select “As scheduled” option and set the days, time, etc.

3. Default Delay, Additional Alarm Delays (Optional)

By default, when the normal state of your electric load changes, an alarm is tripped after a default 10 second delay. You can add more delay so any temporary changes can be ignored. You can also reduce this default 10 second delay by adding a negative value in the optional alarm trip field. Eg 1: -4 will take 4 seconds out of the 10 second delay, making the default delay to be 6 seconds.

Eg 2: You want to know if your sump pump keeps running for more than 2 minutes each time it turns on. To do this, simply add 120 seconds in the “Alarm Delay” field. This means, if your pump turns on, runs for a minute and turns off, it will not alert you. It will alert you only if the pump keeps running for more than 2 minutes.

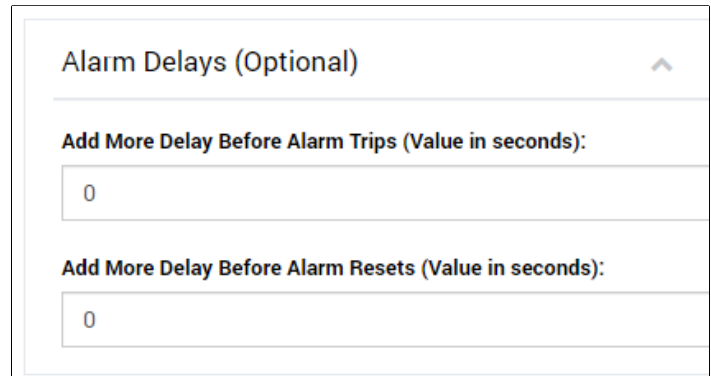

Alarm Delays (Optional)

Add More Delay Before Alarm Trips (Value in seconds):

0

Add More Delay Before Alarm Resets (Value in seconds):

0

Similarly, if you have a cycling load like a refrigerator, you can use this delay to ignore normal ON/OFF cycles by adding an alarm delay. See examples below.

Sample Configuration 1

In this example, we will setup Proteus C5 to monitor a normally OFF electric load. Eg: Sump pump monitor. C5 can be used to know when the sump pump turns on, and off. To achieve this,

1. Set Load normal state to “Normally OFF”
2. Set schedule to ON Always.
3. Leave Alarm Delay to 0. Save settings.

To test this setup, simply lift the float on your pump to turn the pump on. The light on the clamp on module will turn orange. In few seconds, the base unit will start beeping. Alarm notifications will be sent. After you drop the float down, pump stops, and the alarm should reset.

Sample Configuration 2

In this example, we will setup Proteus C5 to monitor a normally ON electric load. Eg: Main Electric Motor. C5 can be used to know when the sump pump turns off, and on. To achieve this,

1. Set Load normal state to “Normally ON”
2. Set schedule to ON Always.
3. Leave Alarm Delay to 0. Save settings.

To test this setup, simply turn the motor off. The light on the clamp on module will turn off. In few seconds, the base unit will start beeping. Alarm notifications will be sent. After you the motor back on, the alarm should reset.

Sample Configuration 3

In this example, we will setup Proteus C5 to monitor a cycling electric load. Eg: Refrigerator. Note that unlike **Normally ON** loads, even though the refrigerator remains cooled, the compressor which is the electric load, goes ON and OFF based on the temperature inside, just like a thermostat in your home. This means that even if the compressor (electric load) is off, the refrigerator may be working normally and you don’t need an alert just because the compressor turned off. The compressor is going to turn back on when the temperature inside the refrigerator falls and the cycle continues. You want to ignore these cycles and want to be alerted if the compressor remains OFF when it should be turning ON.

The Learning Stage

The settings, as well as the cycle frequency of each refrigerator (or similar cycling electric loads) differs from one another. So, we need to find out how often the load (compressor in this case) turns on, and how long it remains off before turning off. To find this out,

1. Set Load normal state to “Normally ON”
2. Set schedule to ON Always.
3. Leave Alarm Delay to 0.
4. Uncheck “Enable Buzzer”.
5. Uncheck “Email me/ Text me”. Save settings.

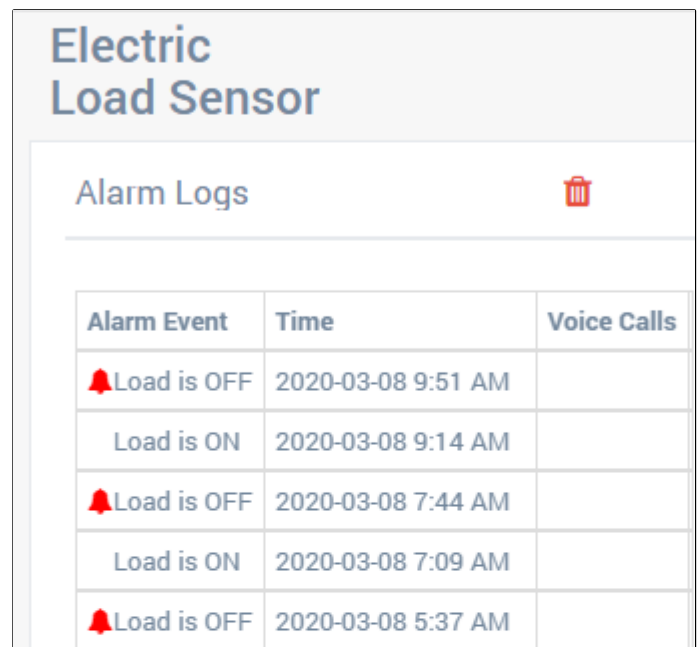

The reason for disabling the buzzer and email alerts is because this is a learning stage. The sensor will trip multiple times but they are not valid alarms and you don’t want the buzzer to go off/ notifications be sent during this time.

Let this configuration run for few hours. After that, login to the sensor cloud (proteushub.com), and click on “Alarms” for your sensor.





Electric Load Sensor

Alarm Logs 

Alarm Event	Time	Voice Calls
 Load is OFF	2020-03-08 9:51 AM	
Load is ON	2020-03-08 9:14 AM	
 Load is OFF	2020-03-08 7:44 AM	
Load is ON	2020-03-08 7:09 AM	
 Load is OFF	2020-03-08 5:37 AM	

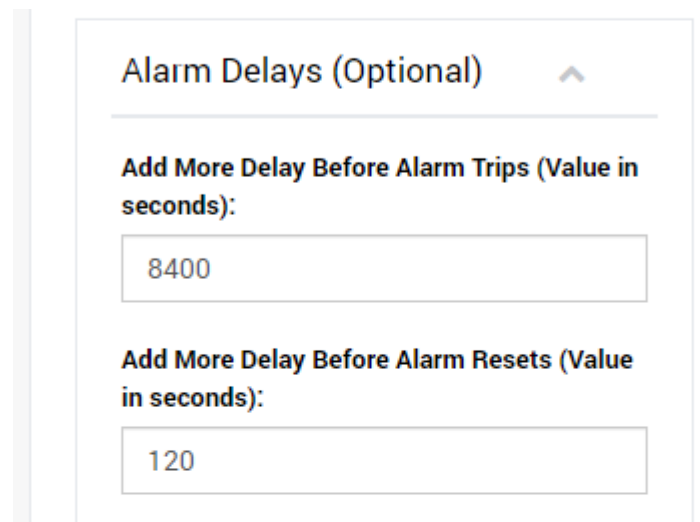
Look at two consecutive “Load is ON” events. In this case they are at 7:09 AM and 9:14 AM. This gives a cycle time of 125 minutes. Check with a few more consecutive events. You will likely find that they are not always the same but never the less within a reasonably close range. Say 120 min, 129 mins, etc.



Alarm Delays (Optional) 

Add More Delay Before Alarm Trips (Value in seconds):

Add More Delay Before Alarm Resets (Value in seconds):

To cover for this variance, let's add a few more minutes, round it up to 140 minutes. Converting this to seconds, you get $140 * 60 = 8400$ seconds. Enter 8400 in the Alarm Delay field. To avoid immediate resets, add a short namesake delay of 120 seconds in the Alarm reset delay field.

You can enable buzzer and email/ text alerts at this stage. Save settings.

At this stage, the normal cycles of your refrigerator will be ignored by the Proteus C5 sensor and you will be notified if the refrigerator does not turn on within its normal/expected cycle.

Monitoring Power Outage

While the primary purpose of Proteus C5 is to monitor electric loads by monitoring the current flowing through the power cord of an electrical equipment, Proteus C5 also has the ability to notify you if power or wifi is out. This is how it works.

- Proteus keeps sending heart beat signals to the cloud once per minute.
- If the outlet in which Proteus is plugged in loses power, or if the wifi network goes down, Proteus won't be able to send data to the cloud.
- Once the cloud stops receiving data, it will start counting. If it does not receive any such signals for more than 30 minutes (default delay), you will be notified. You can bring this delay down to 10 minutes if needed on the settings page.

The downside of this method is that even if it was a wifi or network outage, you will be notified that the sensor is down. So, such alerts may not always mean there is a power outage.

To monitor power outage, you can plug in the clamp-on sensor probe directly into the base unit without the cables. Then login to the sensor cloud, and go to the settings tab. Configure the settings as follows.

- Set Electric Load to "Normally Off". This will stop the sensor from going into alarm mode right away.

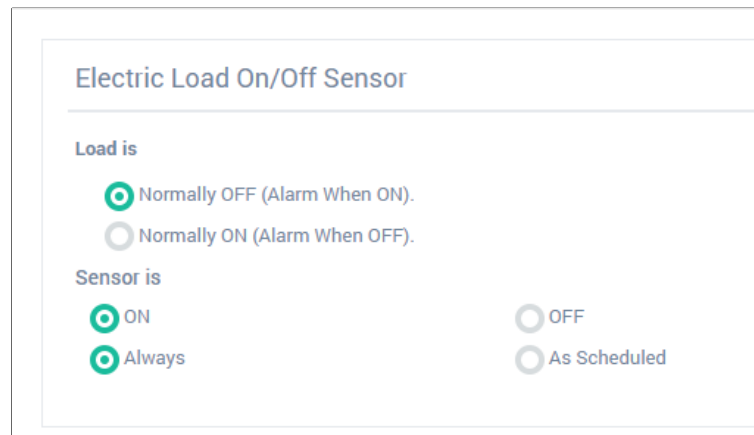

- Now, scroll down to the bottom and set the time delay you want to be notified after a power outage. There is a minimum 10 minute delay needed.

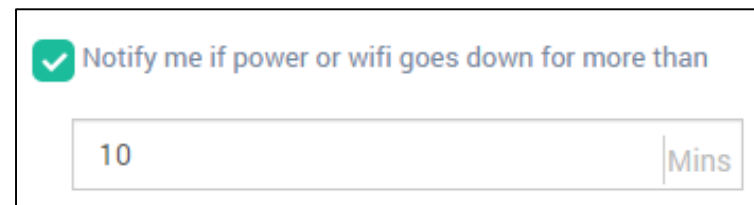

Troubleshooting

While this document shows different use cases of Proteus C5, it is very much possible that you have a unique application that is not covered in this document. Here are some quick tips for basic troubleshooting.

1. The light on the clamp on sensor is not turning on even though the load is ON.

A. Make sure the clamp on sensor is either connected directly or through the extension cord to the base unit. The clamp on module receives its power from the base unit.

B. Make sure there is at least 500 mA current flowing to the load. To give you an idea, a 15W LED lamp plugged into a 120V outlet only draws 125mA. Your load may be too low.

2. Alarm goes off even though it should not

- A. Make sure that the settings on the cloud are set correctly, based on your specific application.
- B. Make sure to save settings on the cloud. It could take a minute or two for the sensor to sync with the changes you made on the cloud.
- C. After you make settings changes and save them on the cloud, if the alarm state continues after few minutes, try repowering the sensor once.

Additional Help

Still having trouble getting the sensor to work the way you want/ expect it to?

Please contact us and we will assist you to get the sensor up and running.

Email: support@proteussensor.com